

Original Article

## Validation of PC 1000 Hz Reaction Timer with Biopac® MP 36 for Recording Simple Reaction Time

Archana P. Kumar<sup>1</sup>, K. Mahesh Kumar<sup>1\*</sup>, R. Padmavathi<sup>1</sup>,  
K. N. Maruthy<sup>2</sup> and Sundareswaran<sup>3</sup>

<sup>1</sup>Department of Physiology,  
Sri Ramachandra Medical College & Research Institute, Chennai.

<sup>2</sup>Department of Physiology,  
Narayana Medical College and Hospital,  
Chinthareddypalem, Nellore, Andhra Pradesh, India.

<sup>3</sup>Department of Physiology, AIMS, Bhopal.

---

### Abstract

**Background:** In neuropsychological assessment, the time taken by a subject or patient to respond to stimulus provides valuable information about processing in central and peripheral nervous system. Reaction time is a simple and inexpensive method commonly used in cognitive and sport physiology to assess the sensory-motor performance of an individual.

**Objective:** To compare and validate the baseline values of simple reaction time obtained using the PC 1000 Hz reaction timer with Biopac® MP 36.

**Materials and Methods:** 50 healthy subjects (32 males and 18 females) with age of  $22.78 \pm 3.90$  yrs and BMI of  $24.820 \pm 3.59$  kg/m<sup>2</sup> participated. Visual (VRT) and auditory (ART) reaction time were estimated using PC 1000 Hz reaction timer and Biopac® MP 36 separately for minimum of three trials each.

**Results:** There was no significant difference found in ART and VRT values of the subjects estimated by PC 1000 Hz and Biopac® MP 36. A strong significant ( $P < 0.01$ ) correlation was found in ART ( $r = 0.92$ ) and VRT ( $r = 0.94$ ) in between the devices. Bland Altman plot also showed that variations for VRT and ART were within the acceptable range.

**Conclusion:** The present validation study recommend that the assessment of simple reaction time for auditory and visual stimulus by PC 1000 Hz reaction timer is reliable one and compared with other techniques it has more advantages such as portable in nature and simplicity to use either in laboratory or in field oriented study for the evaluation of psychomotor and cognitive function.

---

**\*Corresponding author :**

Dr. K. Mahesh Kumar, BNYS, M.Sc, Ph.D, Assistant Professor, Department of Physiology, Sri Ramachandra Medical College & Research Institute, Porur, Chennai – 600 116. Mail id: doctor.mahesh1985@gmail.com

(Received on August 03, 2018)

## Introduction

Reaction time (RT) testing is used in the field of neurophysiology and psychology as a simple and sensitive tool for cognitive assessment for both healthy individuals and patients (1). It is the time taken for the appearance of rapid voluntary reaction by an individual following a stimulus, either auditory or visual. It contains sequence of processes such as giving out of the stimulus, making decision about it and programming a response. So the following events contribute to the latency of sensory signal passing through both in central and peripheral neuronal pathways, cognitive and perceptive processing of the stimulus, motor response signal traversing both central and peripheral pathways and end organ activation like muscle contraction (2). The speed and quality of information processing can be evaluated by using one (simple RT) or more (choice RT) stimuli. Also, both tasks are a measure of sustained attention from an executive functions perspective. However, choice RT task creates more stress among the respondents for decision making. Therefore, choice RT is longer than simple RT (3). It has been observed that various factors such as age (4, 5), caffeine rich foods, drugs (6), various metabolic disorders (7), socioeconomic condition (SES) (8), physical activity (PA), lifestyle patterns (9, 10) and various form of yoga practices (11) are associated with changes in the RT. The first report of visual and auditory RT parameter was documented in the 19<sup>th</sup> century (12) and it was dependent on mechanical apparatus with average simple visual and auditory RT (mean values between 150 and 250 ms) (13). Currently available digital devices are costly. In addition, they are not compact enough to be used in field or community based large sample settings. To overcome these limitations, we designed a novel instrument a PC 1000 Hz reaction timer which is cost effective, portable, very easy and simple to use in field or lab based studies. Therefore, the present study was conducted to compare and validate the RT parameters obtained using PC 1000 Hz reaction timer against Biopac® MP 36 for validation.

## Materials and Methods

The present study was done on 50 healthy subjects

(32 males and 18 females, Mean age =  $22.78 \pm 3.90$  years and BMI  $24.82 \pm 3.59$  kg/m<sup>2</sup>). Institutional ethics committee approval was obtained and written informed consent was obtained from all participants after explaining the study protocol. Subjects with known acute or chronic medical illness, chronic smokers, and alcoholics were excluded from the study. All the recordings were done in between 9 AM-11 AM after 2-3 hrs of light breakfast. Subjects were not allowed to have caffeinated foods and drinks on the day of recording since that may have influenced the parameters under observation. Estimation of VRT and ART were done in PC 1000 Hz and Biopac® MP 36 separately for minimum of 3 trials each. Of these three readings, best one was chosen as an estimate of reaction time.

### Audacity

Audacity®, open source software, was used in the study for recording and displaying the RT estimates in real time (14). Using the software installed on a computer obviates the need of a separate external analog to digital converter and microprocessor. Also, the software can display real time signals with parameters of time and amplitude.

### PC 1000 Hertz Reaction Timer:

The device was built in-house by the investigators for determination of auditory and visual reaction time. It had a soft key for start and stop function with 1000 Hz square wave oscillator. It consisted of two components - E&S - connected to each other. The start button in the first component (E) was controlled by the examiners and was out of the view of the subjects.

The subjects operated the second component (S) which had a stop button. Red LED light was used for visual stimulus as it persists for a long time in retina. 1000 hertz tone delivered through head phone was used for the auditory stimulus. Both component E& S were connected to a personal computer running Audacity® software. Audacity® software recorded the reaction time in wave format (accuracy in the range of 0.001 sec).

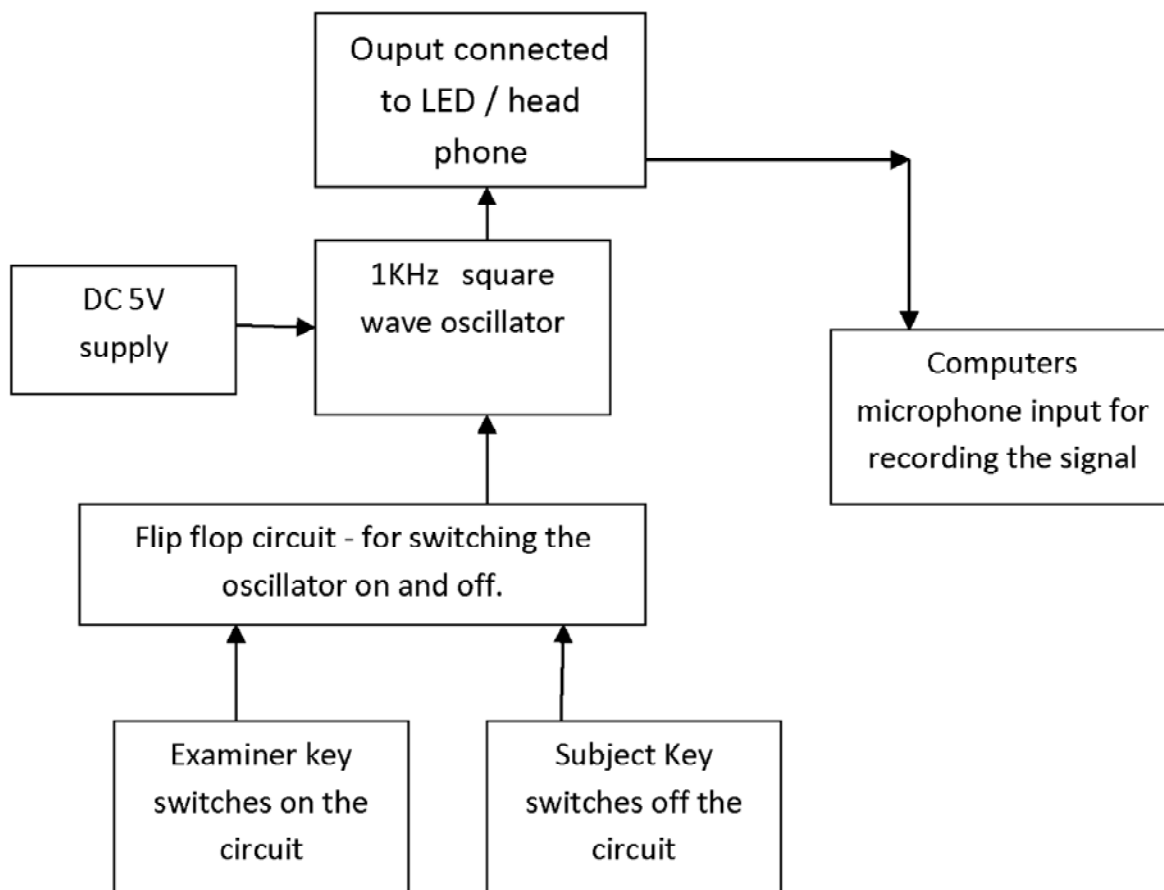

Fig. 1: Block diagram of the Auditory and Visual reaction time measuring device using Audacity® software.



Fig. 2: PC 1000 HZ Reaction timer device.

#### Visual Reaction Time (VRT) Recording:

Examiner provided the visual stimulus by pressing the START button in first component (E) which was out of the view of the subject. As soon as subject saw red light in the instrument, he/she had to press

the STOP button in second component (S). VRT was thus recorded in Audacity® software in wave format.

#### Auditory Reaction Time (ART) Recording:

Examiner provided the auditory stimulus by pressing the START button in first component (E) which was out of the view of the subject. The subject was instructed to press the stop button (S) as soon as he/she heard the sound (1000 Hertz tone) through the headphone connected to it. ART time was estimated in Audacity® software.

A minimum of three trials were given for both VRT and ART measurement. The graphical representation for VRT and ART is shown in Figure 3.

#### Statistical analysis

Normality of data was tested using Kolmogorov-

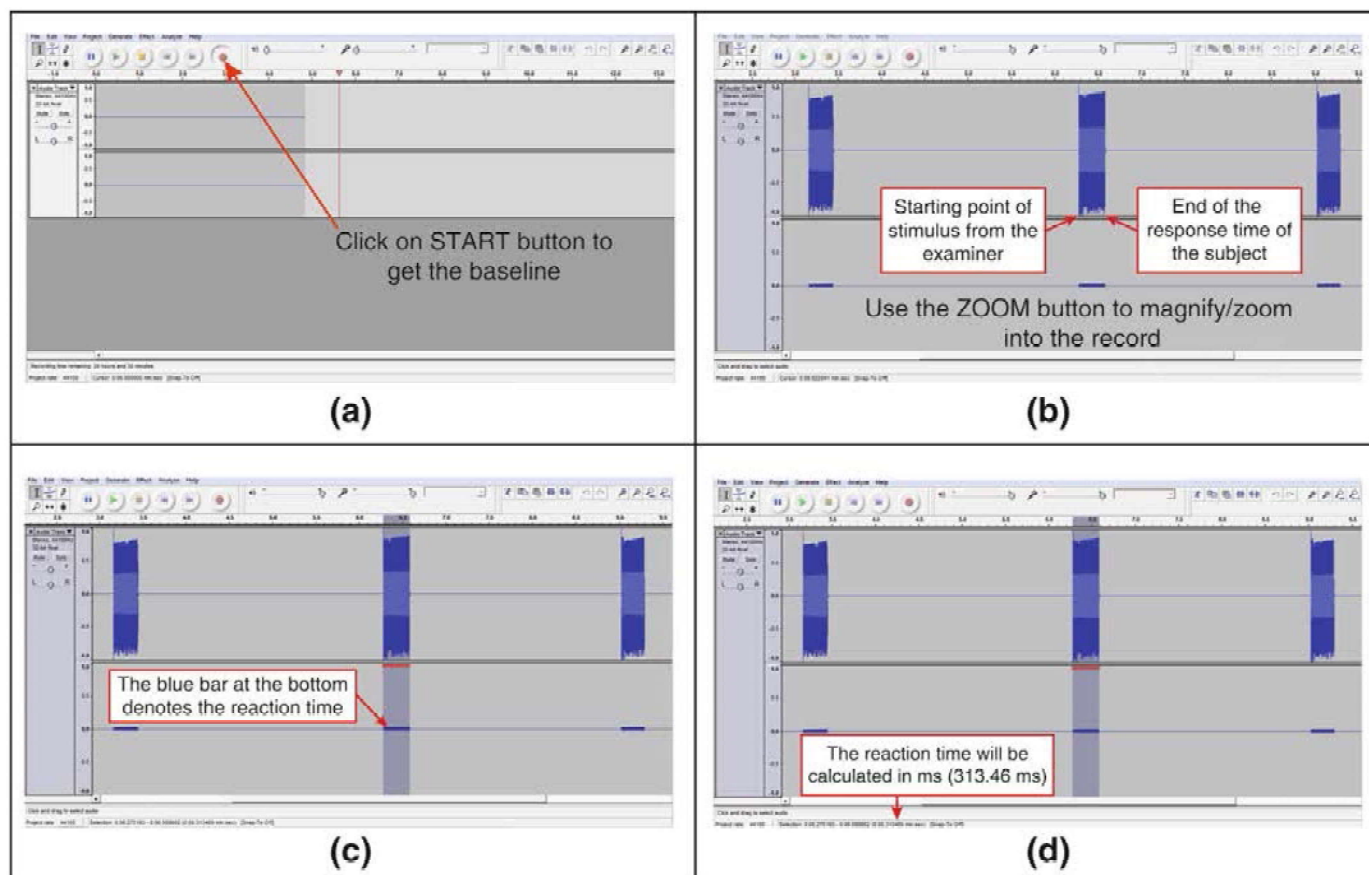

Fig. 3: Graphical flow chart for Reaction time estimation in Audacity® software with PC 1000 Hz reaction timer.

Smirnov test. A *p* value of > 0.05 indicated normal Gaussian distribution. The data presented with mean and standard deviations. Independent *t* test was used to compare the reaction time values obtained by the both devices. Association between values of the two devices was made using Pearson correlation (*r*) test for parametric distribution. *r* > 0.75 was considered as strong correlation, *r* value between 0.5 to 0.75 was considered as moderate correlation and *r* < 0.5 was a weak correlation. *P* < 0.05 was the significance level for all tests. R statistical software version 3.1.2 was used for the statistical analysis.

## Results

Table I show the ART and VRT values of the subjects estimated by PC 1000 Hz and Biopac. There was no significant (*P* > 0.05) difference found in the reaction time estimated between the two devices.

A strong significant (*P* < 0.01) correlation was found in ART (*r* = 0.92) and VRT (*r* = 0.94) in between the devices. Gender based comparison (Table II) also showed no statistical difference in reaction time

TABLE I: Reaction time in PC 1000 Hz and Biopac® MP 36.

Reaction time	PC 1000 Hz	Biopac®	<i>P</i> value	Correlation coefficient( <i>r</i> )
VRT (ms)	224.68±16.52	221.43±19.20	0.25	0.92
ART (ms)	217.59±13.68	211.62±17.65	0.45	0.94

Data expressed as Mean±SD. unpaired *t* test was used to compare the mean. VRT - Visual reaction time, ART - Auditory reaction time.

TABLE II: Comparison of Reaction time between Male and Female subjects.

Reaction time	Male		Correlation coefficient (r)	Female		Correlation coefficient (r)
	PC 1000 Hz	Biopac®		PC 1000 Hz	Biopac®	
VRT (msec)	217.84±11.50	215.32±13.56	0.97	226.80±18.72	225.69±14.27	0.94
ART (msec)	201.55±12.52	199.74±11.56	0.96	216.69±19.56	213.77±15.89	0.92

Data expressed as Mean±SD, Pearson correlation test was used. VRT - Visual reaction time, ART - Auditory reaction time.

parameters in between the devices.

Pearson correlation coefficient showed (Fig. 4 & 5) significant strong correlation in male ( $r=0.97$ ,  $r=0.96$ ) and female ( $r=0.94$ ,  $r=0.92$ ) of the both devices. Bland Altman plot (Fig. 6 & 7) also showed that variations for VRT and ART within the acceptable range.

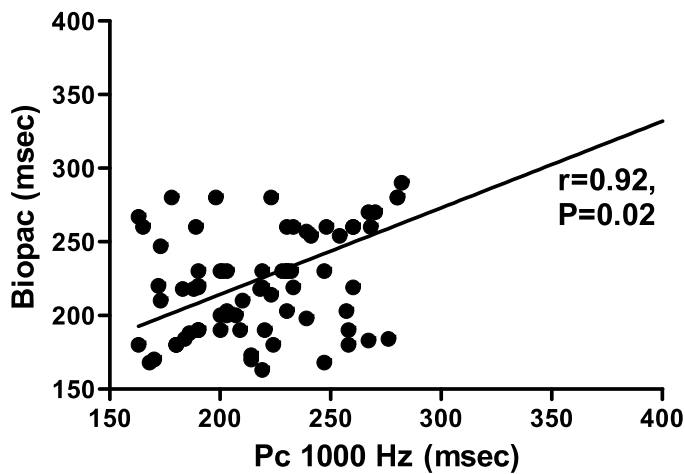

Fig. 4 : Correlation of VRT between PC 1000 Hz and Biopac®.

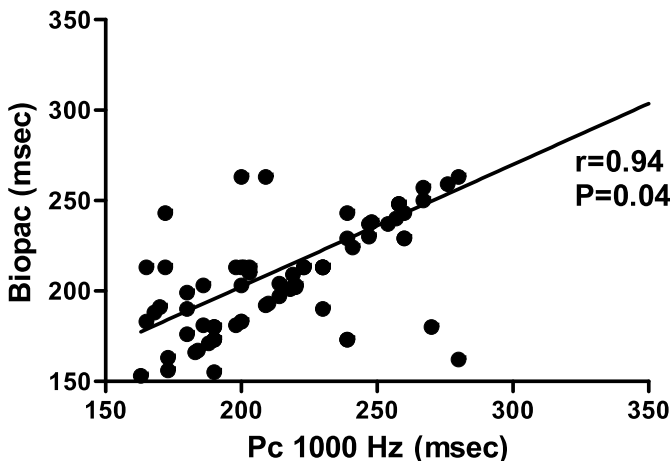

Fig. 5 : Correlation of ART between PC 1000 Hz and Biopac®.

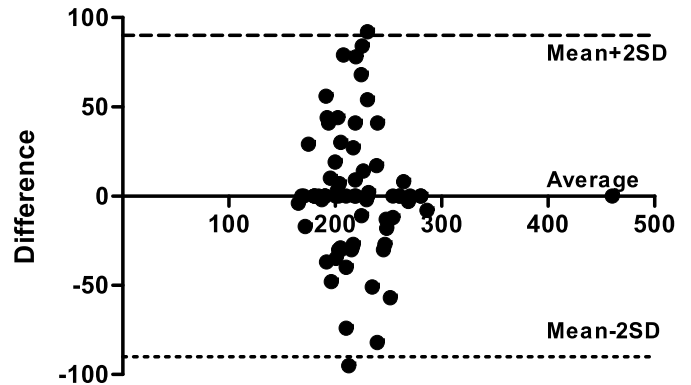

Fig. 6 : Bland-Altman of VRT: Difference vs average.

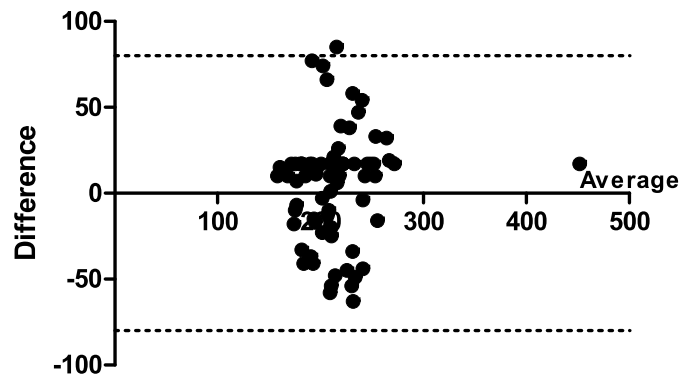

Fig. 7 : Bland-Altman of ART: Difference vs average.

## Discussion

Our results suggest that simple reaction time test carried out by PC 1000 Hz reaction timer would be a valid measure of sensory motor association and cognitive function. This study is the first empirical validation of the timing accuracy of sound card based (audacity® software) reaction timer device compared with gold standard Biopac® system. The linear correlation between the PC 1000 Hz reaction timer

and Biopac® MP 36 (Pearson  $r = 0.90$ ;  $p < 0.01$ ) revealed a strong concurrent validity, despite diverse technical modalities. The normative values in this study are distinct of values from earlier studies confirming that simple reaction time measures show reliable values across the instruments and subjects. These simple visual and auditory reaction time mainly reveal the rate of nerve conduction (15) and physiological properties of white matter of the neurons (16). It is the time interval between a stimulus and the subject's reaction and the stimulus can be in any form of the sensory stimulus like light, sound, temperature, touch and pain. In this device the subjects would give their response by pressing the button for both auditory and visual stimulus. (17). Measurement of RT has various physiological significance and is a simple and non-invasive test for assessing the peripheral as well as central neural function (18). Generally VRT being higher to ART is due to the occurrence chemical changes in the receptors of the retinal for the visual response. Also the visual sensation is carried via various collateral pathways to different association areas and hence a greater delay in comprehension of visual stimulus as it is interpreted in a more complex and elaborate fashion. The receptors gets stimulated in the retina and the organ of corti is not same and the perception

of the stimulus also has some degree of variation (19, 20).

The advantage of using this instrument is simplicity, portable in nature, and no need of power supply. It's an excellent device for community base, field oriented and large population studies. The audacity® sound recording software is also available free and has multiple options to edit and save the recording. Following the development and validation of the present device, it can be used for research purposes and in clinics with people who suffer disorders in concentration, focus level, working and short memory and speed of information processing.

### Conclusion

The present validation study recommends that the assessment of simple reaction time for auditory and visual stimulus by PC 1000 Hz reaction timer with audacity® software is a reliable one. Compared with other device this has more advantages such as portable in nature and simplicity to use and it's may serve as an excellent device for community base, field oriented and large population studies for the evaluation of psychomotor and cognitive function.

## References

- Jakobsen LH, Sorensen JM, Rask IK, Jensen BS, Kondrup J. Validation of reaction time as a measure of cognitive function and quality of life in healthy subjects and patients. *Nutrition* 2011; 27: 561–570.
- Botwinick J, Thompson LW. Premotor and motor components of reaction time. *Jour of Experi Psycho* 1966; 71: 9.
- Magill RA, Anderson DI. Motor learning and control: Concepts and applications. New York: McGraw-Hill; 2007; 280–289.
- Esmailzadeh S. Reaction time: does it relate to weight status in children? *HOMO-Journal of Comparative Human Biology* 2014; 65: 171–178.
- Moradi A, Esmailzadeh S. Association between reaction time, speed and agility in schoolboys. *Sport Sciences for Health* 2015; 11: 251256.
- Durlach PJ, Edmunds R, Howard L, Tipper SP. A rapid effect of caffeinated beverages on two choice reaction time tasks. *Nutritional Neuroscience* 2002; 5: 433–442.
- Smith AP, Brice C, Leach A, Tiley M, Williamson S. Effects of upper respiratory tract illnesses in a working population. *Ergonomics* 2004; 47: 363–369.
- Noble KG, Norman MF, Farah MJ. Neurocognitive correlates of socioeconomic status in kindergarten children. *Develop Sci* 2005; 8: 74–87.
- Murray NP, Russoniello C. Acute physical activity on cognitive function: a heart rate variability examination. *Applied psychophysiology and biofeedback*. 2012; 37: 219–227.
- Sibley BA, Etnier JL. The relationship between physical activity and cognition in children: a meta-analysis. *Pediat Exer Sci* 2003; 15: 243–256.
- Vijayalakshmi P, Surendiran A. Effect of slow and fast pranayams on reaction time and cardiorespiratory variables. *Indian J Physiol Pharmacol* 2005; 49: 313–318.
- Moradi A, Esmailzadeh S. Simple reaction time and obesity in children: whether there is a relationship? *Environmental Health and Preventive Medicine* 2017; 22: 2.
- Seashore SH, Seashore RH. Individual differences in simple auditory reaction times of hands, feet and jaws. *Journal of Experimental Psychology* 1941; 29: 342.
- Team A. Audacity (Version 1.3. 12) [Computer software]. Retrieved; 2017.

15. Fontani G, Corradeschi F, Felici A, Alfatti F, Migliorini S, Lodi L. Cognitive and physiological effects of Omega-3 polyunsaturated fatty acid supplementation in healthy subjects. *European Journal of Clinical Investigation* 2005; 35: 691–699.
16. Tuch DS, Salat DH, Wisco JJ, Zaleta AK, Hevelone ND, Rosas HD. Choice reaction time performance correlates with diffusion anisotropy in white matter pathways supporting visuospatial attention. *Proceedings of the National Academy of Sciences of the United States of America*. 2005; 102: 12212–12217.
17. Wagenmakers EJ, van der Maas H, Jensen AR. *Clocking the mind: Mental chronometry and individual differences*, Elsevier, Amsterdam 2006; 92.
18. Mohan M, Thombre D, Das A, Subramanian N, Chandrasekar S. Reaction time in clinical diabetes mellitus. *Indian J Physiol Pharmacol* 1984; 28: 311–314.
19. Jain A. *Manual of Practical Physiology for BDS*: Arya publications; 2003; 178.
20. Niruba R, Maruthy K. Assessment of auditory and visual reaction time in type 2 diabetics-a case control study. *Al Ameen J Med Sci* 2011; 4: 274.